



Typical Applications

- Scour monitoring (visual feedback from the structure environment)
- Accident recording
- Barge collision monitoring: works with Resensys wireless vibration SenSpot™
- Serves as a data acquisition gateway (SeniMax™) to gather SenSpot™ sensors' data and transmit them to server through cellular connection

Benefits

- **Long lifetime:** solar charged battery pack
- **A Stand-alone IoT Device:** all-in-one device capable of taking photos, collecting data and uploading them to the remote server
- **Easy mounting:** Flange mount or adhesive tape
- **Ingress Protection:** IP66, weatherproof and protected against rain, snow, and UV exposure
- **Maintenance free:** Self-powered by a solar panel. No battery replacement, calibration or post-installation maintenance is required

Specifications

- **Dimensions:** 204.45mm (8.05") × 159.26mm (6.27") × 127.25mm (5.01")
- **Weight:** 1.5Kg (3.3 lbs.)
- **Operating temperature:** -40°C to +65°C (-40°F to +150°F)
- **Wireless communication:** Cellular (CDMA, GPRS, HSPA+, LTE), Wi-Fi (IEEE 802.11 b/g), Satellite
- **Wireless communication range:** 1.0km (0.62mi) free space
- **Pixels:** 0.3Mega
- **Angel of view:** 90°(Default), 170°/150°/120°/60°/45°/30°/15°
- **Image resolution:** 640 × 480, 320 × 240
- **Data format:** JPEG
- **Minimum illumination:** 1 Lux
- **Night image:** Black and white
- **Night vision range:** 10m (33ft)
- **Triggering delay:** 1100ms
- **Triggering source:** interval timer, shock (vibration) or wireless command from a Resensys wireless SenSpot™ (for monitoring collision or strain event).

Description

SeniMax™ Wireless Camera provides an easy way to install a stand-alone solution for visual feedback and condition awareness. The main enclosure and the solar panel can be easily mounted with either flange or adhesive mount. The device comes with a high-capacity lithium-ion battery charged by a solar panel. It does not require battery replacement so that once installed, it is almost maintenance free. The whole product meets IP66 specification (completely weatherproof) so it is an excellent choice for applications that require the sensors to be installed some outdoor places which are often hard to reach.

The SeniMax™ Camera is equipped with a JPEG camera from Spinel Electronics. The resolution can be as high as 640 × 480 (0.3Mega Pixel). To save power, the camera is triggered by an event signal (e.g., motion, vibration, strain, etc.). For instance, the camera can be configured when there is high strain caused by a heavy truck.

Installation

Wireless transceiver box comes with mounting flanges. It can be installed either with screws and anchors through the flange holes or with VHB adhesive tape (for steel and smooth surfaces).

Wireless Transceiver Dimensions

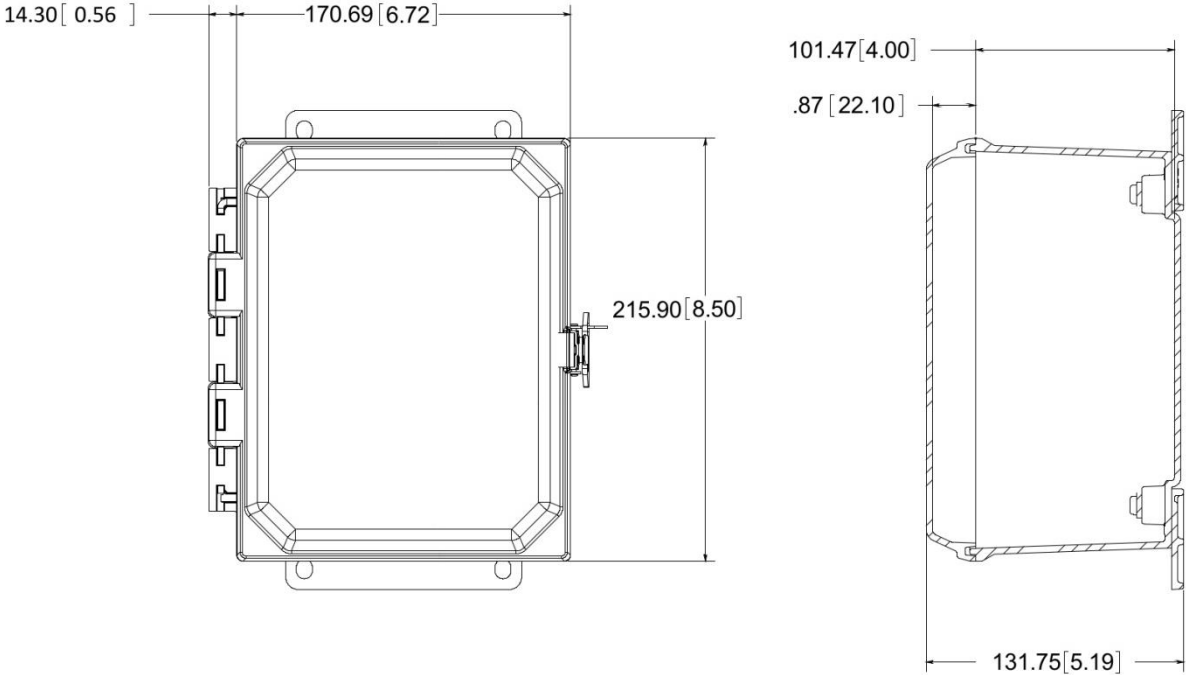

Figure 1: Wireless transceiver dimensions for solar powered camera. All dimensions are in mm [inch].

A sample picture taken by Wireless Solar Powered Camera



Figure 2: A typical picture taken by Resensys Wireless Solar Powered Camera indicating the field of view when there is a barge floating in close proximity of the fender/pier